

MarinaGuard[®] MG-1

Ground Fault Monitoring Panel
For Marina Shore Power



MarinaGuard® MG-1

Ground Fault Monitoring Panel

For Marina Shore Power



MarinaGuard® MG-1.3 Panel

Device features

- Satisfies requirements of NEC Article 555.35, "Ground-Fault Protection"
- UL 1053 Listed Ground-fault Protection
- Preset to 30 mA trip level, steplessly adjustable to required value; adjustable trip time for coordination
- TEST and RESET push button on front
- POWER LED on front
- Strobe light for easily visible alarm indication; flashes on a ground fault or internal failure
- Contact outputs for connection to a shunt-trip circuit breaker
- Type 4X rated, lockable enclosure with weep fitting
- Internal circuit breaker protection; suitable for connection to a feeder tap to minimize tampering

Certifications



GROUND FAULT SENSING AND RELAYING EQUIPMENT

E478610

Product description

To help prevent Electric-Shock Drownings, MarinaGuard UL Listed Ground-Fault Protection Panels detect ground faults in feeder and branch circuits of electrical systems in marinas, boat yards, docking facilities, floating buildings, and similar locations. MarinaGuard panels satisfy the 2023 edition requirements of National Electrical Code 555.35 (A) & (B)(1), 555.53 & 682.15 (B); and Canadian Electrical Code 78-052. The MG-1 features a lockable Type 4X rated enclosure, with a test and reset button, a power LED, and a strobe light on the enclosure for clear indication that a fault has occurred.

Applications

- Shore power for marinas
- Feeder and branch monitoring
- Systems which must satisfy the requirements of NEC, Article 555.3 (2017 & earlier); 555.35, 555.53, 682.15 (2023 edition); and CE Code 78-052

Function

MarinaGuard panels detect ground faults with a measuring current transformer (CT). One CT is required per feeder or branch to be monitored (see ordering information). The feeder / branch active conductors pass through the current transformer window. For example, in 240/120 V shore power applications, both line conductors and the neutral must be passed through the CT.

If a ground fault is detected, the MarinaGuard will trip the connected shunt-trip circuit breaker and the strobe light will flash. Once the fault has been cleared, holding the reset button for at least 2 seconds will clear the alarm lights and return the panel to the normal state, allowing the circuit breaker to be reset.

If an internal malfunction occurs, the strobe will flash but the connected circuit breaker may not trip.

The MG-1 powered contact outputs must be connected to a shunt-trip circuit breaker.

MG-1 MarinaGuard Front Panel

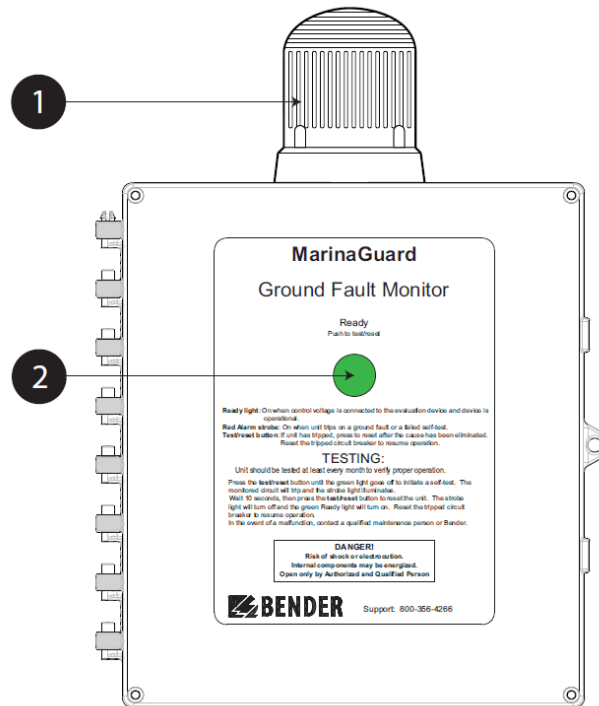

1	<p>Strobe light: Flashes red when circuit is tripped due to a ground fault, internal fuse has failed, or self-test has failed.</p>
2	<p>Ready light / Test and Reset button: Illuminates green when panel is powered and internal RCM420 is in the normal condition. Push and hold the button for > 1.5 s to initiate a functional test. Refer to Section 4.3 (Page 24) in the MG-1 manual for what occurs during a self-test. When tripped, momentarily press the button to reset the MG-1 and return to the normal state. After the ground fault is eliminated, external trip devices can be reset.</p>

Applying Power

To apply power, close the circuit breaker or disconnect to the 120 VAC control power entering the panel. The MarinaGuard will immediately power on. The green READY light will illuminate.



NOTE: During startup, the strobe may flash briefly. This is normal power-up operation.

Performing a Functional Test

- Press and hold the TEST/RESET button for at least two seconds. The strobe light will activate and the connected circuit breaker will trip.
- Wait 10 to 15 seconds until the internal self-test is completed.
- Momentarily Press the TEST/RESET button. The strobe light will turn off.
- Manually reset the connected circuit breaker.



CAUTION: Performing a functional test will trip the circuit interrupting device and de-energize the monitored circuit.

Wiring

- The MarinaGuard panel requires a 120 VAC supply voltage. Bring the supply conductors into the panel through a water-tight fitting and connect the line conductor (L) to the top of the terminal block labeled Control L1 and the neutral conductor (N) to the top of the terminal labeled Control N.
- Install a separately purchased Bender measuring current transformer in the site electrical equipment, passing the active line and neutral conductors through the CT window. Connect the CT-secondary terminals, through a water-tight fitting, to MG-1 terminal Current trans k and Current trans I. Use minimum AWG 24, maximum AWG 12 THHN wire.
- The MG-1 output contact at terminals labeled Shunt L1 and Shunt N are normally open and powered with 120 Vac to operate a shunt-trip protection device such as a shunt-trip circuit breaker. Connect these terminals, through a water-tight fitting, to the shunt-trip device configured to de-energize the protected circuit.

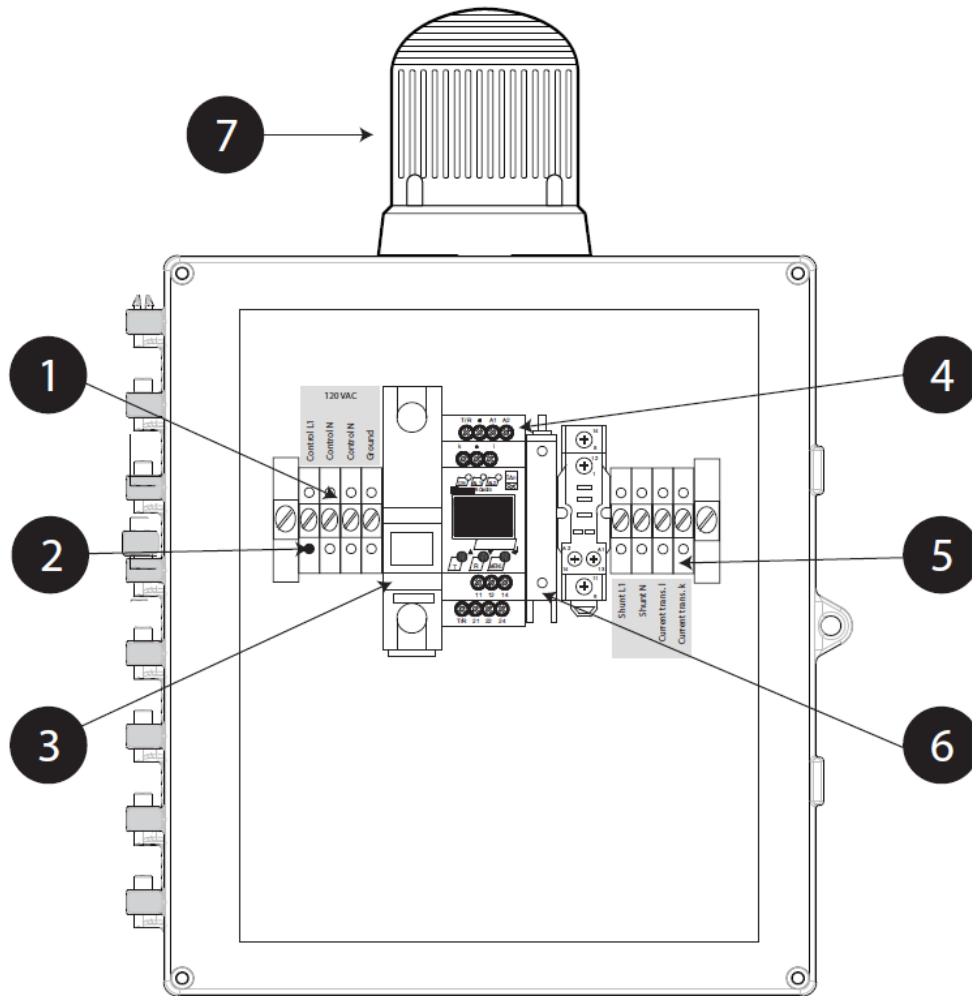

1	Terminal blocks for external 120 VAC control power and ground
2	Power indicating light - illuminates when control voltage is applied to panel, even if internal circuit breaker is open
3	Branch-circuit-rated circuit breaker - protects internal components and external trip circuit
4	RCM420 ground fault relay
5	Terminal blocks for external trip circuit and current transformer
6	Fuse holder - contains fuse protecting RCM420
7	Strobe light - flashes when ground fault is detected and circuit has tripped, the fuse is open, or the RCM420 malfunctions

Post-Installation Adjustments

MG-1.3 protection uses the installed RCM420-D-2 ground-fault monitor. Aside from possible field adjustments by a qualified person to the trip-level setting (default = 30 mA) and trip-delay setting (default = 100 ms), do not adjust the factory settings. For settings adjustment instructions, see the MG-1 technical manual or the RCM420 technical manual.



WARNING: Do not change any other settings other than what is shown in this chapter. Incorrect settings may result in death, personal injury, or damage to equipment.

Enclosure Dimensions

Dimensions shown in inches (mm). Mounting feet are shown installed. A weep hole is provided on the bottom of the panel to comply with NEC 555.32 (2020 & 2023 editions) and 555.11 (2017 and earlier editions). The enclosure is lockable.

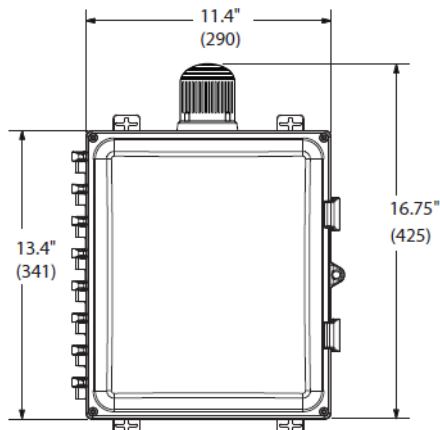

Front View with Strobe

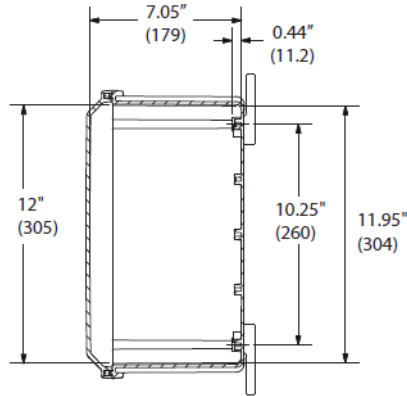

Side View

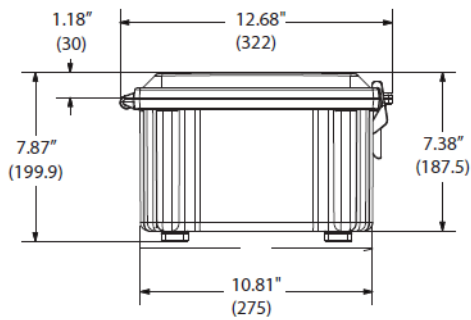

Bottom View

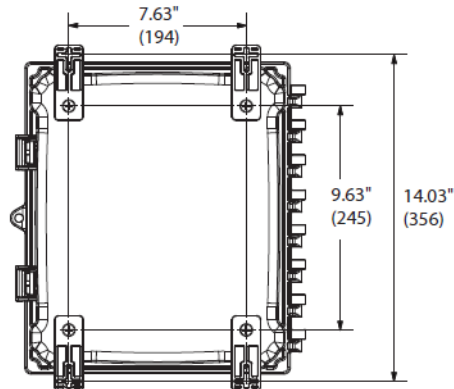

Rear View

Model	Weight
MG-1.3	9.4 lb. (4.3 kg)

Technical Specifications

Supply	120 VAC
Relay protection fuse	5 A type 3AG fast acting
Internal overcurrent protection	15 A UL 489 circuit breaker
Ground-fault monitor	RCM420-D-2
Pickup range	10 mA to 10 A (30 mA factory setting)
Trip delay range	0 to 10 s (100 ms factory setting)
Current	1 A RMS, 5 A peak
Maximum protected-circuit voltage	600 Vac
Current withstand rating	160 A, 1 s
Dimensions (W x H x D)	11.4 x 16.75 x 7.87" (290 x 425 x 200 mm)
Weight	9.4 lb (4.3 kg)
Shipping weight	10 lb (4.5 kg)
Compatible current transformers	CTAC series
Compatible trip device	shunt trip, 120 Vac
Field connections	Copper wire only, 22 to 14 AWG, 60/70 C
CT-input and shunt-trip terminals, torque	5.0 to 5.6 lb-in (0.6 Nm)

Ordering Information

Part No.	Channels	Outputs	Ordering No.
MG-1.3	1	1	B541300778

Current transformers

One current transformer is required for an MG-1. Current transformers must be large enough to accommodate all normally energized conductors (including the neutral if it is used) centrally though the opening.

Part No.	Shape	Core Type	Opening Size	Ordering No.
CTAC20	Circular	Solid	.79" (20 mm)	B 981 10005
CTAC35	Circular	Solid	1.38" (35 mm)	B 981 10007
CTAC60	Circular	Solid	2.36" (60 mm)	B 981 10017
CTAC120	Circular	Solid	4.72" (120 mm)	B 981 10019
CTAC210	Circular	Solid	8.27" (210 mm)	B 981 10020