

TOTAL PANEL WEIGHT
 3kVA: 275 LBS (125 Kg)
 5kVA: 295 LBS (134 Kg)

GENERAL NOTES

- Galvanized ROHS compliant steel box, constructed in accordance with UL50.
- Front Trim, Type 304 SS with #4 polish finish.
- Bolt-On chassis fastens to studs in box
- Filler plates provided for branch breaker spaces

ITEM	DESCRIPTION			
1	ISOLATION TRANSFORMER			
	KVA	VOLTAGE		FREQ.
		PRIMARY	SECONDARY	
	3	120	120	60
5	208	208		
	277	220		
480*				
*5 kVA only				
INTERIOR ASSEMBLY				
2	PRIMARY MAIN BREAKER:			
3	BRANCH BREAKERS*			QTY
		15 A		
		20 A		
		30 A		
4	LINE ISOLATION MONITOR (LIM2010)			
5	CP-LIM2010 CONNECTOR PLATE			
6	GROUND BUS			
7	COMMUNICATION GATEWAY:		<input type="checkbox"/> YES	<input type="checkbox"/> NO
8	FAULT LOCATION SYSTEM:		<input type="checkbox"/> YES	<input type="checkbox"/> NO
9	CURRENT MONITORING SYSTEM:		<input type="checkbox"/> YES	<input type="checkbox"/> NO
10	TRANSFORMER LOAD MONITOR:		<input type="checkbox"/> YES	<input type="checkbox"/> NO
11	RECEPTACLE PLATE CONFIGURATION: N/A			
12	FRONT TRIM: T6826R			
13	BACKBOX: B662406F			

* 16 BREAKERS MAX 2 POLE, 10 KAIC

PROJECT:		TITLE:	
SALES ORDER		DWG. NO.	
QTY.			
MODEL			
ARTICLE #		REV	
DRAWN BY			
APPROVED BY		SHEET 1 OF 1	
 420 Eagleview Blvd. Exton, PA 19341-1116 1-800-356-4266			

ITEM	DESCRIPTION
1	ISOLATION TRANSFORMER
2	PRIMARY MAIN BREAKER
3	BRANCH CIRCUIT BREAKERS (16 BREAKERS MAX, 2 POLE, 10 KAIC)
4	LINE ISOLATION MONITOR (LIM2010)
5	CP-LIM2010 CONNECTOR PLATE
6	GROUND BUS

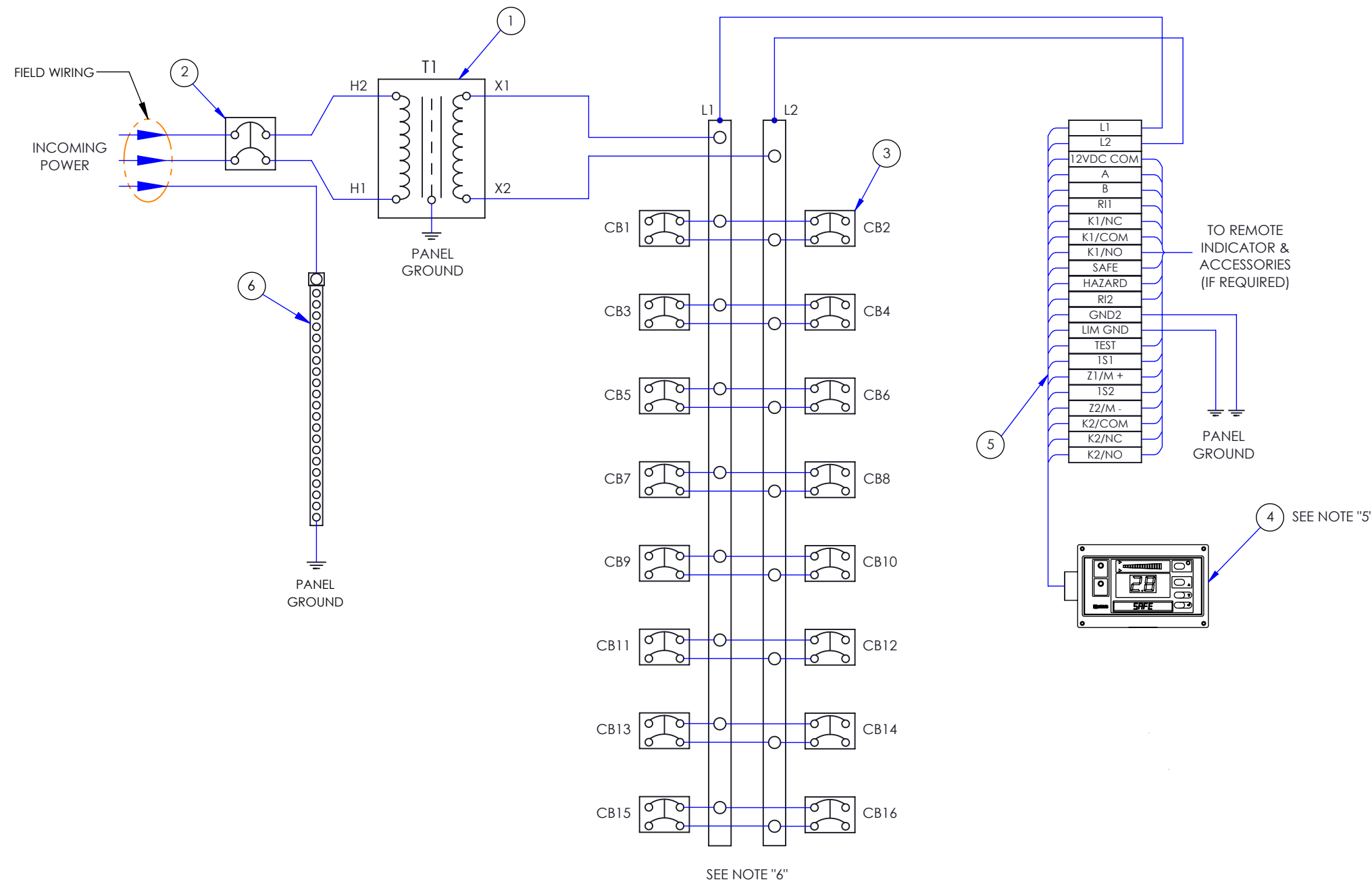

NOTES:

1. Type XHHW wire with a dielectric constant of less than 3.5 is recommended for all branch circuit field wiring.
2. Polarity shall be observed in all instances.
3. Size of all conductors shall be in accordance with all UL, NEC, NFPA and State Fire Marshall requirements.
4. All remote indication circuitry shall be low voltage and will not contribute leakage to the system.
5. When other panels/units with RS-485 communication are added onto panel, slide switch "R" on bottom of unit must be positioned in the "off" position. If additional RS-485 related equipment is not connected, slide "R" switch must be in the "on" position.
6. Quantity of branch breakers (CB1 - CB16) shown for reference only. See elevation drawing for specific values provided.

TITLE: MIP WIRING DIAGRAM STANDARD	DRAWN BY T. COYLE	11/05/19	 420 Eagleview Blvd. Exton, PA 19341-1116 1-800-356-4266	DWG. NO. 442 0005	REV 2
	APPROVED BY A. JOHNSON	11/05/19		SHEET 1 OF 1	