

# LINETRAXX<sup>®</sup> CTAS series

Divisible measuring current transformer





### Product description

The divisible measuring current transformers of the CTAS series allow the measuring current transformer to be opened by means of a locking button and place them around the conductors to be monitored. This enables easy retrofitting in existing systems.

The divisible, highly sensitive CTAS series measuring current transformers in combination with RCM or RCMS series residual current monitors and evaluators convert AC currents into an evaluable measurement signal.

They are also suitable for use in insulation fault location systems for IT systems (EDS). The current transformers measure the locating current generated by a PGH locating current injector or an ISOMETER® iso685. In combination with EDS series insulation fault locators, the locating current is converted into an evaluable measurement signal.

The devices are intended for operation in control cabinets or similarly protected environments. For intended operation, observe the specifications in the manual. Any other use than that described in the manual is regarded as improper.

### Device features

#### CTAS... measuring current transformers

- For residual current monitoring systems of the RCMS
- For residual current monitors of the RCM420 series
- For insulation fault locators of the EDS440 series in AC and DC systems

#### CTAS.../01 measuring current transformers

- For insulation fault locators EDS441

### Approvals and certifications



### Wiring diagram

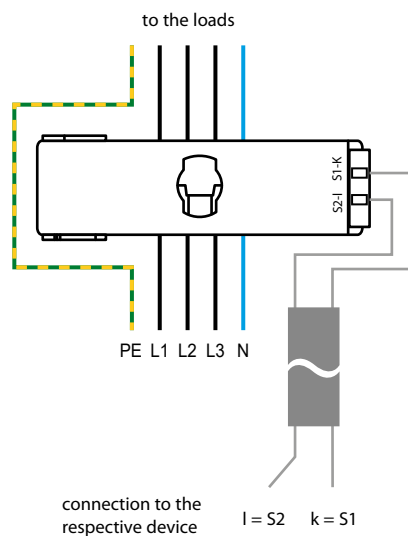

#### CTAS... measuring current transformers

Connection to

- Residual current monitoring systems of the RCMS series
- Residual current monitors of the RCM420 series
- Insulation fault locator of the EDS440 series in AC and DC systems

#### CTAS.../01 measuring current transformers

Connection to

- Insulation fault locator EDS441

### Ordering information

Mounting	Internal diameter	Type	Art. No.
Screw mounting, DIN rail	50 mm	CTAS50	B98110009
		CTAS50/01	B98110012
	80 mm	CTAS80	B98110010
		CTAS80/01	B98110013
Screw mounting	120 mm	CTAS120	B98110011
		CTAS120/01	B98110014

### Selection table

Type	RCM420	RCMS460 RCMS490	RCMS410 RCMS425	EDS440	EDS441
CTAS50	✓	✓	✓	✓	–
CTAS80	✓	✓	✓	✓	–
CTAS120	✓	✓	✓	✓	–
CTAS50/01	–	–	–	–	✓
CTAS80/01	–	–	–	–	✓
CTAS120/01	–	–	–	–	✓

### Accessories

Description	Art. No.
Mounting clip <sup>1)</sup>	B98110015
Mounting bracket	B98110016

<sup>1)</sup> Included in the scope of delivery of the CTAS50(/01) and CTAS80(/01). For CTAS120(/01) reduced mechanical conditions apply.



**Dimension diagrams**

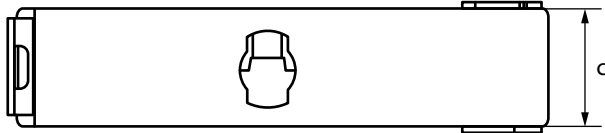
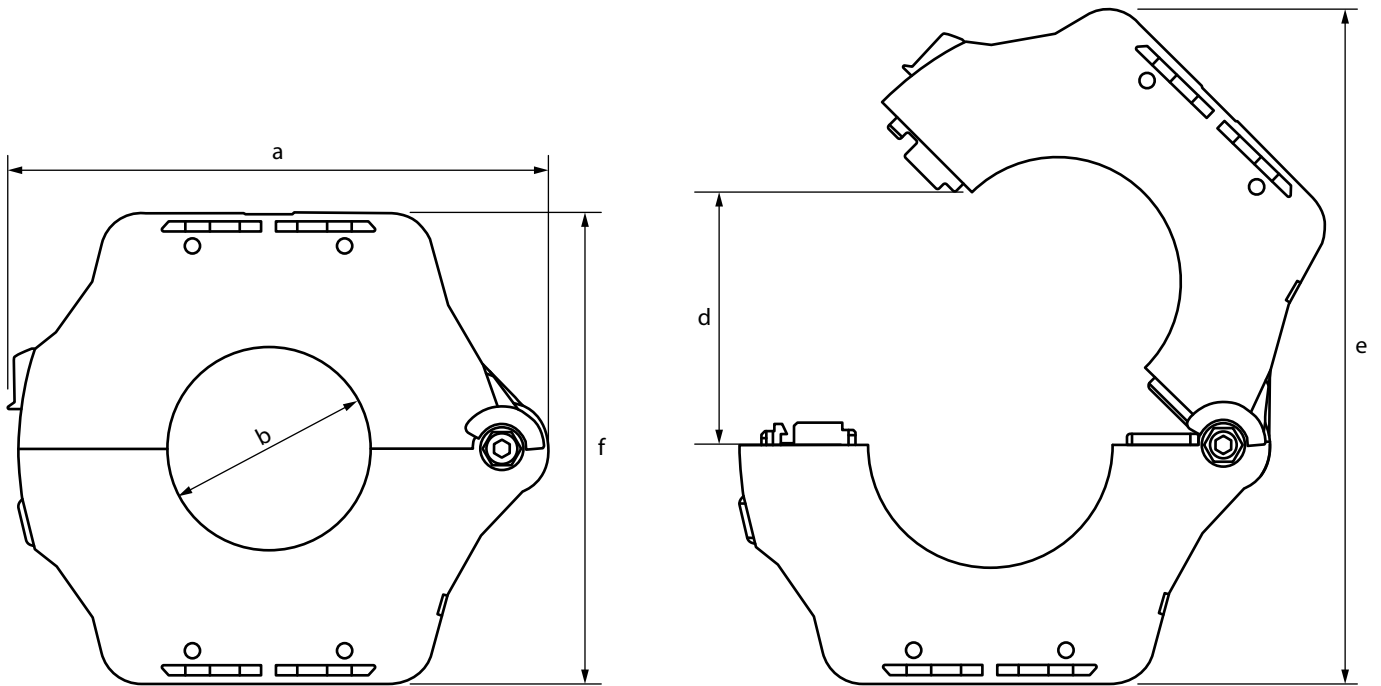

Type	Dimensions (mm)						Weight in g (gross)
	a	b	c	d	e	f	
CTAS50	133	ø 50	29	77	175	116	425
CTAS50/01	133	ø 50	29	77	175	116	460
CTAS80	177	ø 80	29	108	235	156	875
CTAS80/01	177	ø 80	29	108	235	156	950
CTAS120	225	ø 120	50	150	303	205	1500
CTAS120/01	225	ø 120	50	150	303	205	1550

Tolerance: ±0.5 mm

**Mountings**

**Mounting clip <sup>1)</sup>**

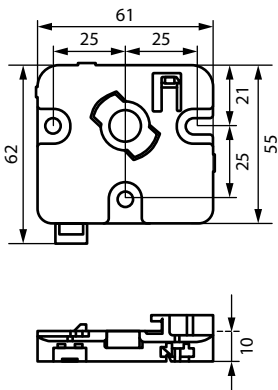

**Mounting bracket**

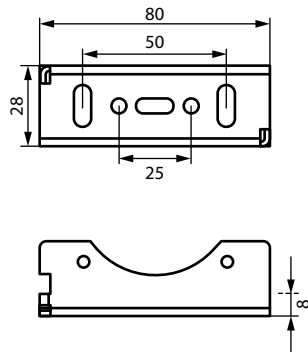

**CTAS120(01)**

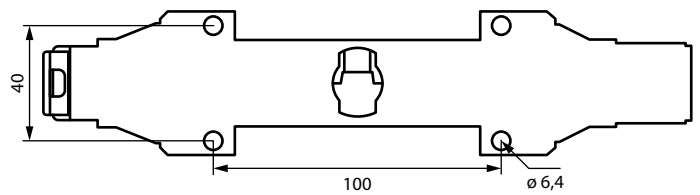

<sup>1)</sup> Mounting clip recommended for CTAS50(01) and CTAS80(01). For CTAS120(01) reduced mechanical conditions apply.

**Mounting clip Ø 50, 80, 120\* mm**

*Mounting*

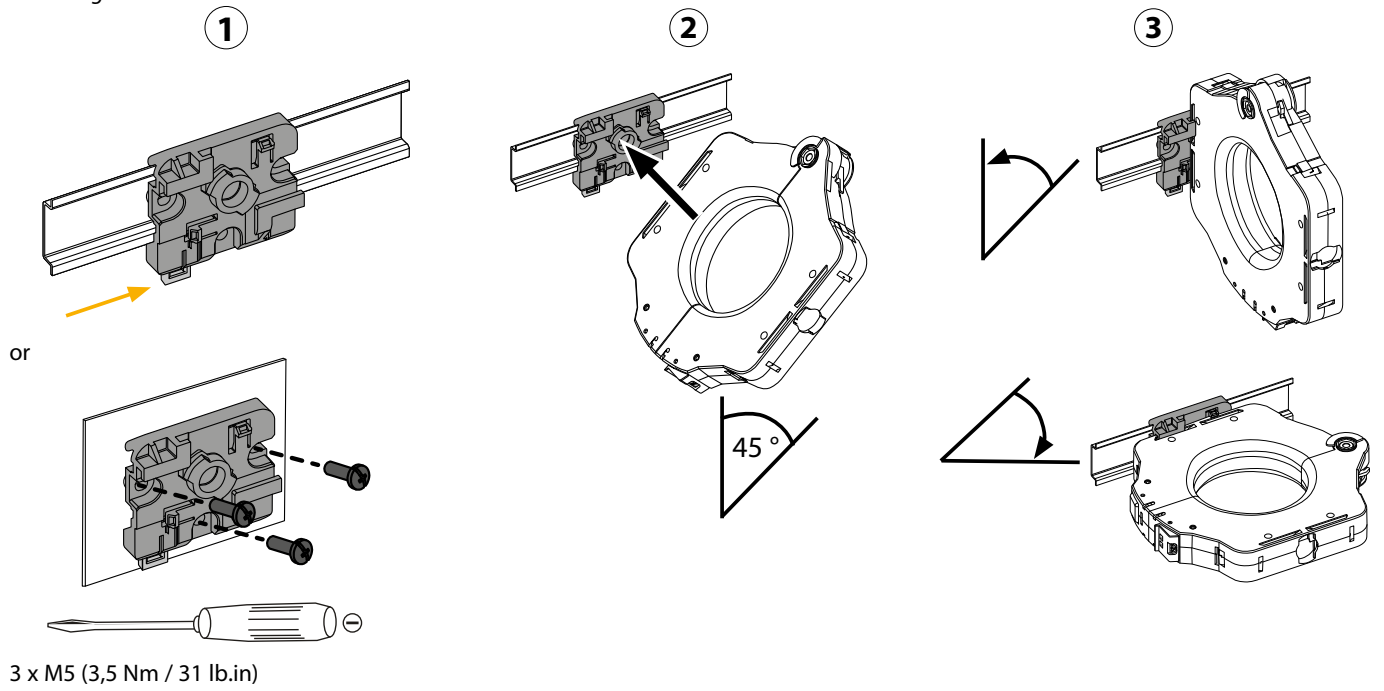

*Dismantling*

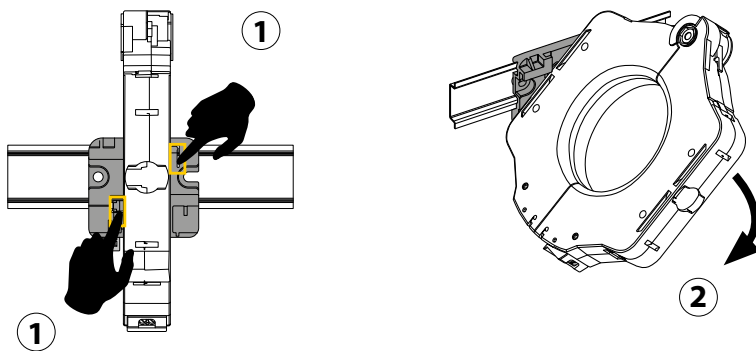

\* For CTAS120(/01) reduced mechanical conditions apply with this mounting.

**Mounting bracket**

Ø 50, 80, 120 mm

1

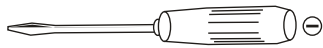
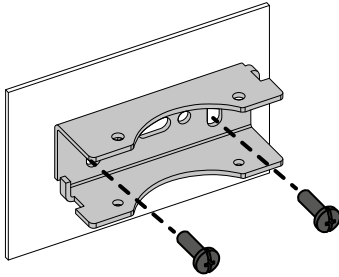

2 x M5 (3,5 Nm / 31 lb.in)

2

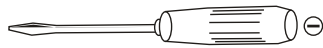
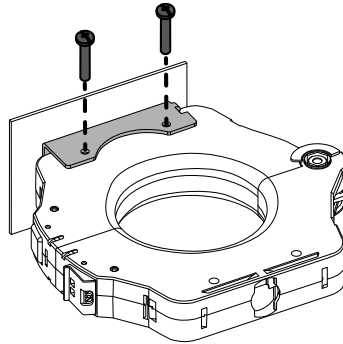

2 x M4 (1,5 Nm / 13.3 lb.in)

Ø 120 mm

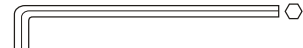
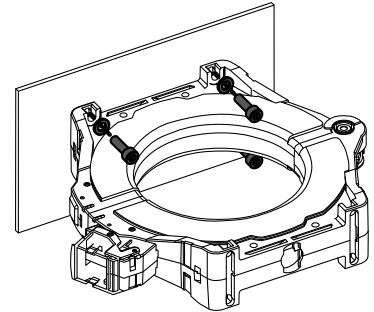

4 x M4 (3,5 Nm / 31 lb.in)  
4 x Flat washer Z type

**Cable tie\***

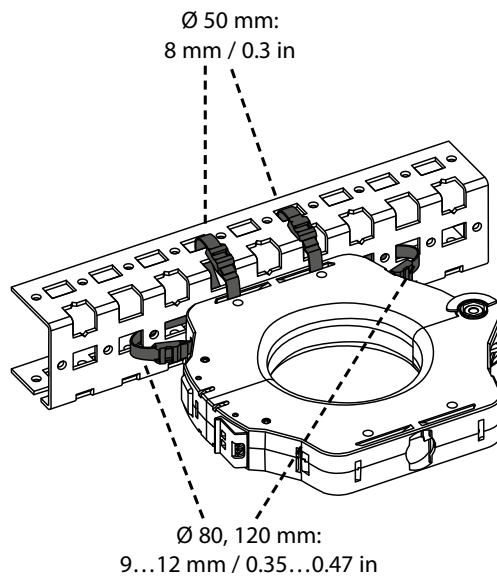

\* Reduced mechanical conditions apply to all CTAS with this mounting.

## Technical data

### Insulation coordination according to IEC 60664-1

Rated voltage	
CTAS50(/01)	500 V
CTAS80(/01)/CTAS120(/01)	630 V
Overtoltage category	III
Rated impulse voltage/pollution degree	8 kV / 3

### Insulation coordination according to IEC 61869-1

Rated voltage	720 V
---------------	-------

### Measuring current transformer circuit

#### CTAS...

Rated transformation ratio $K_r$	600 / 1
Rated continuous thermal current <sup>1)</sup> $I_{cth}$	125 A
Frequency range	42 Hz. ... 3 kHz
Rated short-time thermal current <sup>1)</sup> $I_{th}$	2.4 kA / 1 s
Rated dynamic current <sup>1)</sup> $I_{dyn}$	50 kA / 50 ms
Rated current $I_n$	
CTAS50 at $I_{\Delta n} \geq 30$ mA	85 A
CTAS80 at $I_{\Delta n} \geq 100$ mA	160 A
CTAS120 at $I_{\Delta n} \geq 300$ mA	250 A

#### CTAS.../01

Rated transformation ratio $K_r$	8000/1
Rated continuous thermal current <sup>1)</sup> $I_{cth}$	125 A
Rated short-time thermal current <sup>1)</sup> $I_{th}$	0.36 kA/1 s
Rated dynamic current <sup>1)</sup> $I_{dyn}$	0.9 kA/40 ms
Rated current $I_n$	
CTAS50/01 at $I_{\Delta n} \geq 30$ mA	85 A
CTAS80/01 at $I_{\Delta n} \geq 100$ mA	160 A
CTAS120/01 at $I_{\Delta n} \geq 300$ mA	250 A

<sup>1)</sup> refers to the residual current

#### For UL applications:

Sensing voltage	630 V
Working voltage	30 V
Sensing current difference	
CTAS50(/01)	30 mA
CTAS80(/01)	100 mA
CTAS120(/01)	300 mA

### Environment

Operating temperature	-25...+70 °C
-----------------------	--------------

#### Classification of climatic conditions acc. to IEC 60721

Stationary use (IEC 60721-3-3)	3K23
Transport (IEC 60721-3-2)	2K11
Long-term storage (IEC 60721-3-1)	1K22 (-40...+80 °C)

#### Classification of mechanical conditions acc. to IEC 60721

Stationary use (IEC 60721-3-3)	
Mounting clip	3M12
Mounting bracket	3M12
Transport (IEC 60721-3-2)	2M4
Long-term storage (IEC 60721-3-1)	1M12

### Connection

Connection type	screw-type terminals
Connection properties	
rigid	0.34...2.5 mm <sup>2</sup> (AWG 22...12)
flexible	0.34...2.5 mm <sup>2</sup> (AWG 22...12)
Stripping length	8...9 mm
Tightening torque	0.5 Nm (4.43lb-in)
For UL applications	
conductors	copper or copper-clad aluminium

#### Connection EDS, RCM(S) measuring current transformers

Single wire $\geq 0.75$ mm <sup>2</sup>	0...1 m
Single wire, twisted $\geq 0.75$ mm <sup>2</sup>	0...10 m
Shielded cable $\geq 0.5$ mm <sup>2</sup>	0...40 m
Shielded cable	
recommended	CAT6/CAT7 min. AWG 22
alternatively	Cables, twisted pairs, J-Y(St)Y min. 2x0,8
RCM	shield connected to L conductor, must not be earthed
EDS	shield to PE

### Other

Degree of protection	
internal components (DIN EN 60529)	IP40
terminals (DIN EN 60529)	IP20
Flammability class	UL94 V-0
Number of opening cycles	max. 10
Documentation number	D00452

**Installation instructions**

- Do not route any shielded cables through the measuring current transformer.
- Failure to comply with the installation instructions may result in non-compliance with the tolerances and normative requirements of the connected evaluators.

<p>All current-carrying cables must be routed together through the measuring current transformer.</p>		<p>The primary conductors may only be bent from the specified minimum distance. The minimum bending radius specified by the manufacturers must be observed. * Distance to 90° angle: 2x external diameter of the current transformer</p>	
<p>Never route an existing protective conductor through the measuring current transformer.</p>		<p>The cables must be centred in the measuring current transformer.</p>	
		<p>Internal diameter of the measuring current transformer <math>d2 \geq 2 \times d1</math> (cable diameter)</p>	



**Bender GmbH & Co. KG**

Londorfer Straße 65  
35305 Grünberg  
Germany

Tel.: +49 6401 807-0  
info@bender.de  
www.bender.de



© Bender GmbH & Co. KG, Germany  
Subject to change!  
The specified standards take into account the  
edition valid until 12.2025 unless otherwise  
indicated.