

# AGH520S

Coupling device

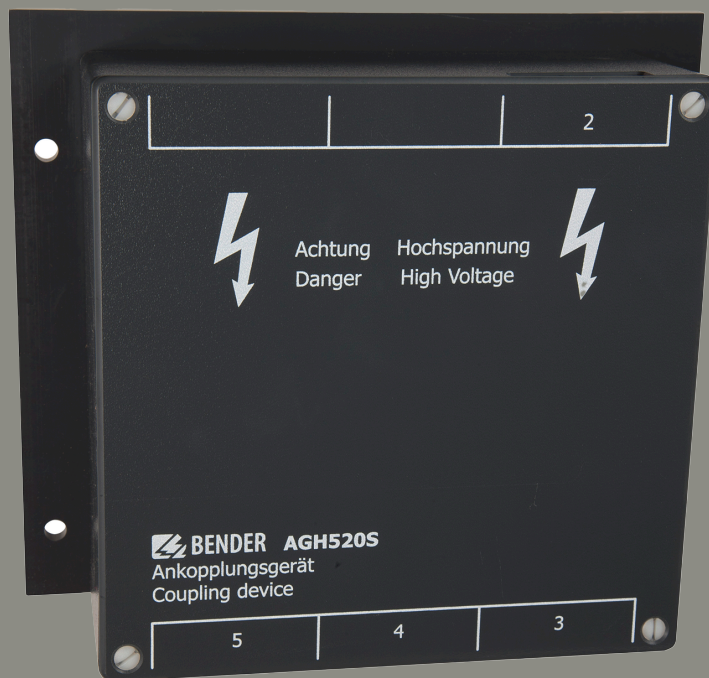

# AGH520S



## Intended use

The AGH520S is used to connect the ISOMETER®s iso685, IRDH275 or IRDH375 to AC systems up to 7.2 kV in online mode. Alternatively, the AGH520S can be used in combination for 7.2 kV AC systems in offline mode. The coupling device is only to be used in combination with the ISOMETER®.

Any other use than that described in this manual is regarded as improper.

## Functional description

The coupling device AGH520S is used to extend the nominal voltage range of the ISOMETER® illustrated in the wiring diagram to 3(N)AC 50...400 Hz, 0...7.2 kV.

## Standards and Certifications

The AGH520S was developed in compliance with the following standards:

- DIN EN 61800-5-1 (VDE 0160-105-1)



## Ordering details

Type	Nominal system voltage $U_n$	Art. No.
AGH520S	3(N)AC 0...7.2 kV, 50...400 Hz	B913033

Wiring diagram

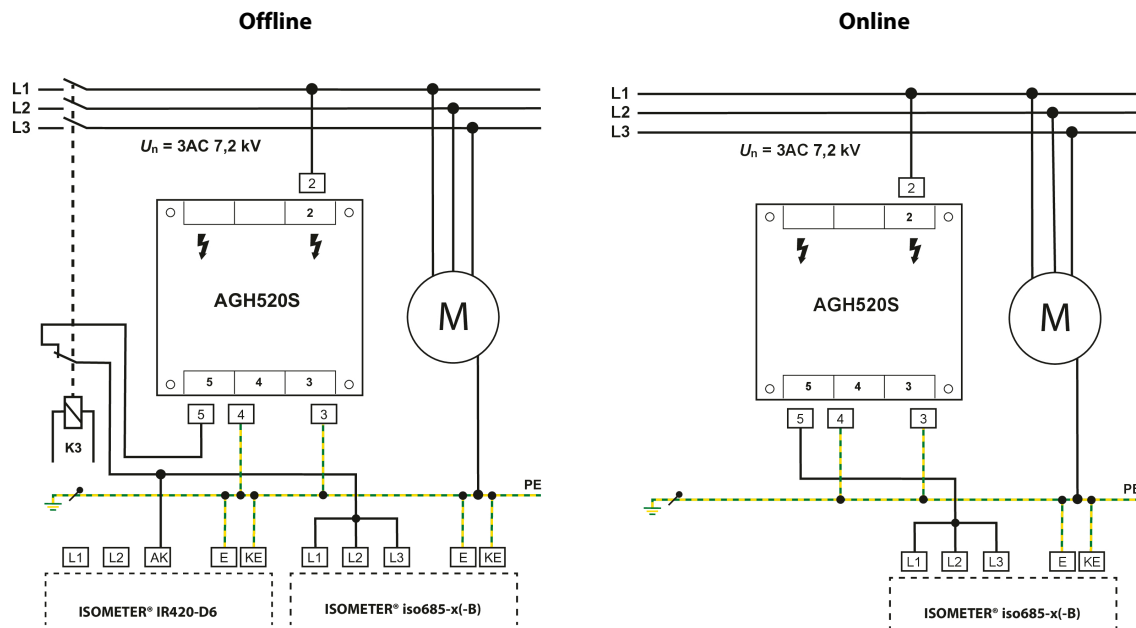

Technical data

Insulation coordination acc. to IEC 60664-1

Rated insulation voltage	AC 6.3 kV
--------------------------	-----------

Voltage test acc. to IEC 60664-1

Voltage impulse test (basic insulation)	AC 35 kV
Overvoltage category	III
AC voltage test (basic insulation)	AC 17.5 kV
Partial discharge test	12 kV

Voltage ranges

Nominal system voltage $U_n$	AC 0...7.2 kV
Nominal system voltage $U_n$ for UL applications	AC 0...6.0 kV
Frequency range of $U_n$	50...400 Hz
Internal DC resistance $R_i$	$\geq 80$ k $\Omega$
Impedance $Z_t$ at 7.2 kV and 50 Hz	$\geq 6$ M $\Omega$

Environment EMC

Ambient temperature	
Operation	-10...+55 °C
Operation UL applications	-10...+45 °C
Storage	-20...+70 °C
Classification of climatic conditions acc. to IEC 60721	3K23
Classification of mechanical conditions acc. to IEC 60721:	
Stationary use (IEC 60721-3-3)	3M11
Transport (IEC 60721-3-2)	2M4
Storage (IEC 60721-3-1)	1M12

Connection

Connection terminal 2 (medium voltage)	screw type terminals
Connection terminals 3-5	screw type terminals
Connection properties rigid/flexible	0.2...4 mm <sup>2</sup> / 0.2...2.5 mm <sup>2</sup>
Conductor sizes (AWG)	24...12
Tightening torque	2.9 Nm

Other

Operating mode	continuous operation
Mounting	any position
Degree of protection	
built-in components (DIN EN 60529)	IP64
terminals (DIN EN 60529)	IP20
Type of enclosure	resin-encapsulated block in housing
Screw mounting	4 x M5
Flammability class	UL 94 HB
Weight	4500 g

## Dimension diagram

---

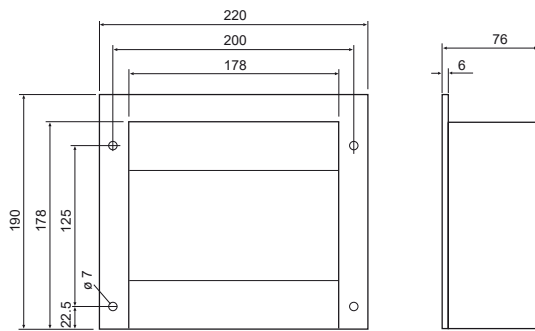

Dimensions in mm



**Bender GmbH & Co. KG**

Londorfer Straße 65  
35305 Grünberg  
Germany

Tel.: +49 6401 807-0  
info@bender.de  
www.bender.de



© Bender GmbH & Co. KG, Germany  
Subject to change!  
The specified standards take into account the  
edition valid until 01.2026 unless otherwise  
indicated.