

Pulp, Paper, and Forest Industries

Electrical Safety Solutions



Paper mills have provided paper products for civilization for centuries. In the 20th century, paper mills around the world began converting from hydro to electric power. With the adoption of electricity came an increased risk of fire due to the dust and paper break fibers which can easily be ignited by a ground fault.

Minimize downtime by immediately locating ground faults.

Bender's ground-fault protection equipment provides advanced personnel, equipment, and fire protection to pulp, paper, and forest product manufacturing facilities. Quickly identify, trend, and locate ground faults to minimize manufacturing downtime and troubleshooting costs. Modern systems often employ variable frequency drives (VFDs), also referred to as adjustable speed drives (ASDs) that require special consideration to be adequately protected. These types of AC/DC loads are best protected by devices capable of monitoring across their entire operating frequency range to capture both AC and DC ground faults. Bender's ground-fault monitoring systems provide this advanced level of protection and can be included in turnkey ground-fault packages.

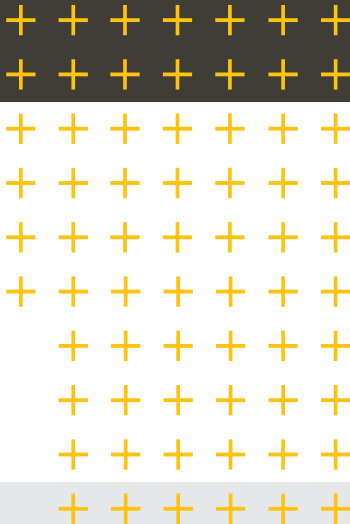

Benefits

Detects faults without interrupting operation

Ground faults or insulation breakdown issues can be **detected and located** while keeping the installation energized.

Reduces maintenance costs

Significant **decrease in maintenance costs** due to the accuracy of detection and decreased need for human interaction with the system.

Automatically locates faults

Automatic fault location eliminates the need for opening branch circuit breakers or disconnecting equipment.

Safety

Ground-fault location at feeders and loads **minimizes employee shock hazards**, and quick repair can **prevent a fire**.



Ungrounded Systems

1 Insulation Condition Monitor iso685-D-P

- Minimizes unplanned outages and eliminates the need to interrupt power to identify faulted circuits
- Allows planning of system maintenance by trending insulation deterioration over time



2 Automatic Fault Locator EDS440

- Monitors feeders to detect which has an insulation fault
- Displays information on the iso685-D-P display



3 Network Communications COMTRAXX® COM465IP

- Complete system overview
- Allows simple and intuitive programming of all connected devices



4 Portable Ground-Fault Locator ISOSCAN® EDS3090 Series

- Automatically identifies fault location of branch and load circuits when paired with iso685-D-P
- Portable ground-fault location equipment in an easily-carried case – includes handheld EDS195PM shown below

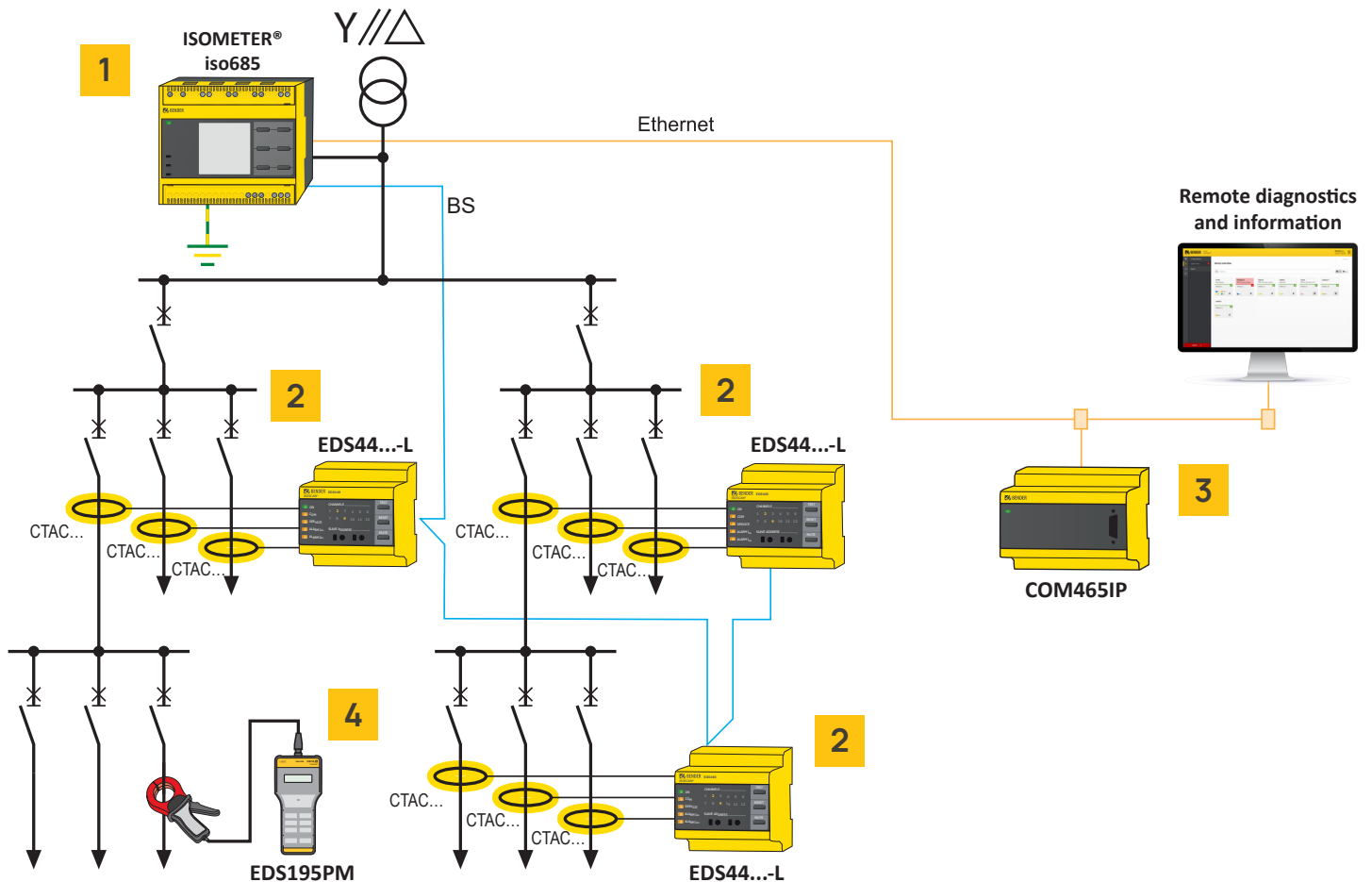

Figure 1: Ungrounded distribution system with Bender ground-fault location system.

High Resistance Grounded Systems

1 Neutral Ground Path Monitor NGRM500 or NGRM700

- Improves safety and reliability with monitoring of the grounding path
- Continuous monitoring of the NGR using active and passive methods - works when the system is online or offline
- Alarms or trips on ground fault



2 Ground-Fault Current Transformers LINETRAXX® CTUB/CTBC Series

- Converts AC and DC currents into an evaluable measurement signal
- Improved ground-fault detection with wider frequency response
- Ideal for VFDs, UPSs, and other non-linear loads
- CTAC series can be used for ac fault detection



3 12-Input Ground-Fault Relay LINETRAXX® RCMS490-D

- Quickly and safely locate faults
- Single device makes it more economical to monitor up to twelve separate channels with individually adjustable alarm pickup levels



4 Network Communications COMTRAXX® COM465IP or CP Gateway Series

- Allows simple and intuitive programming of all connected devices
- Connect multiple Bender devices to a remotely monitored network
- CP Series Gateway features an HMI to view ground-fault current and program devices



Complete solutions available - please refer to Bender's HRG brochure

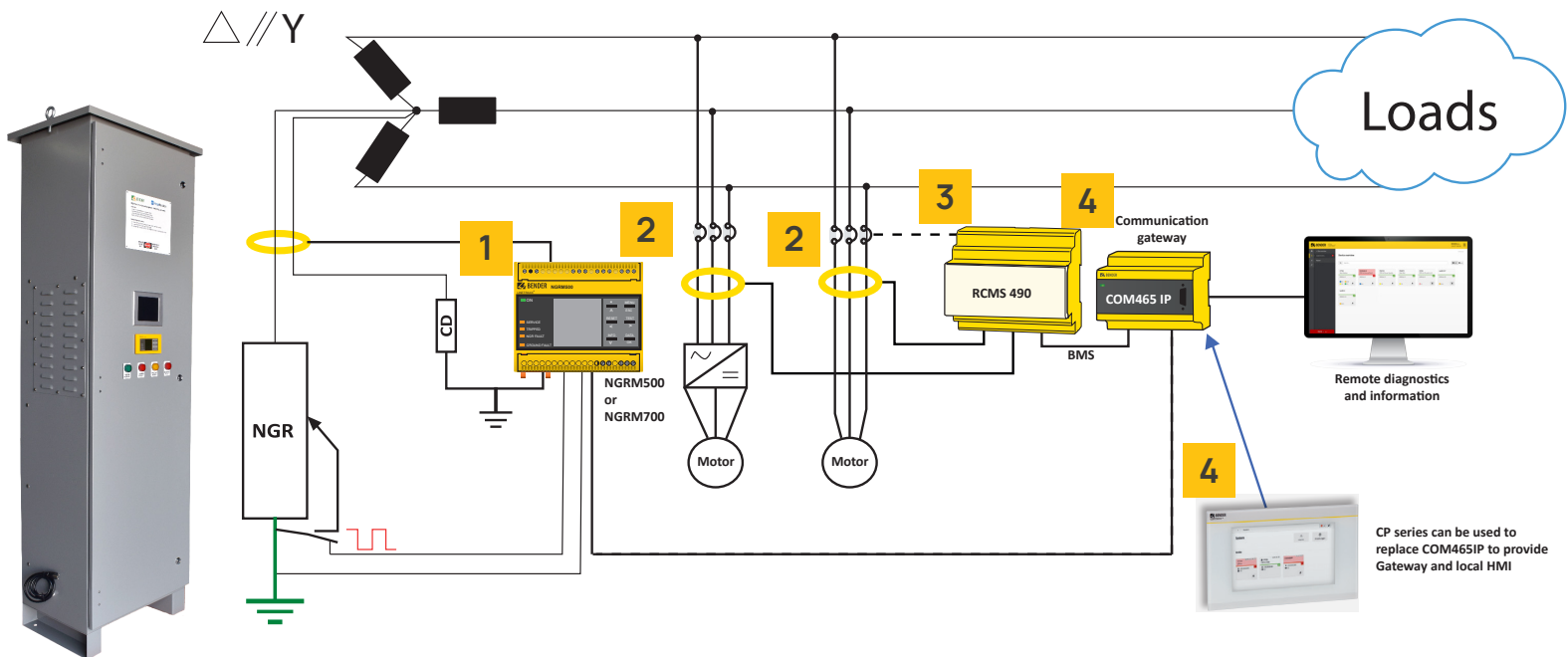
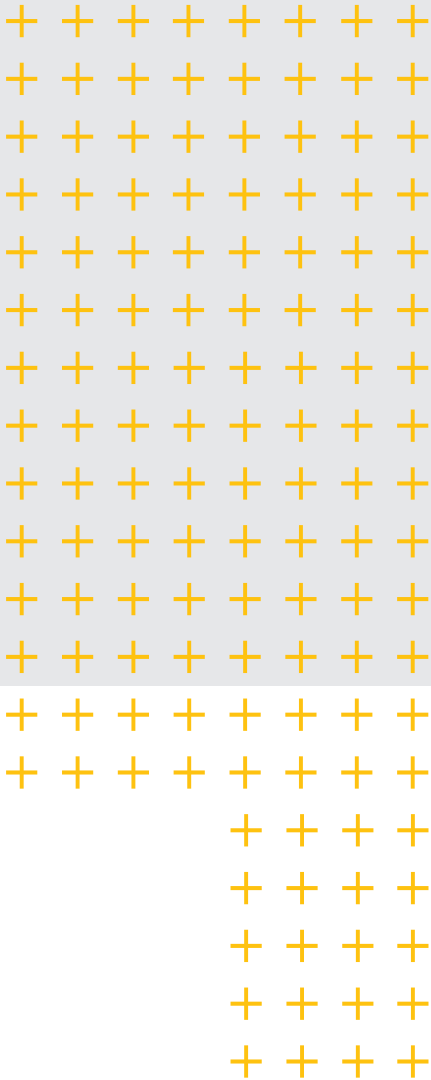

Figure 2: High Resistance Grounded system with Bender ground-fault location system.



Bender Inc.

420 Eagleview Blvd.
Exton, PA
19341

Tel.: 610-383-9200
www.benderinc.com

Bender Canada Inc.

5810 Ambler Drive Unit 1
Mississauga, ON
L4W 4J5

Tel.: 905-602-9990

Revised May 2024

14.22i.REV1

